

Air-Operated Double Diaphragm Pump in Aluminium AODPO20



 **High Quality Italian Made**

Air operated double diaphragm pumps have long been recognized as the most flexible pumps of the industry for handling difficult liquids at relatively low pressures and flows.

- STM Product number AODPO20 in aluminium
- Compression ratio: 1:1
- Max flow-rate: 110 l/min
- Fluid connections: 3/4" BSP
- Fluids compatible: oil - exhausted oil - diesel fuel
- Gasket: nbr

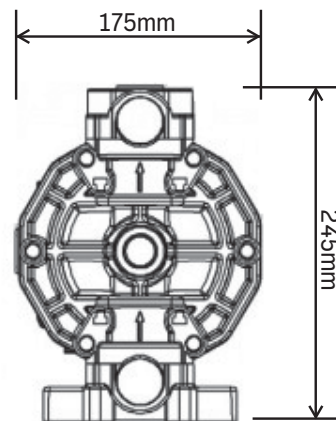
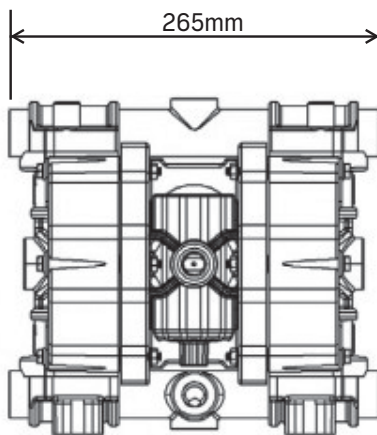

Pump material	aluminium
Diaphragm material	HYTREL
Ball material	SS AISI 316
Compatible fluids	OIL - EXHAUSTED OIL - DIESEL FUEL
Compression ratio	1:1
Fluid inlet-outlet connection	3/4" BSP
Air inlet connection	3/8" BSP
Noise	72 dB
Maximum pressure	8 bar

Viscosity	25000 cps
Max delivery	110 l/min
Temperature	95° C
Weight	7 kg
Max delivery height	80 m
Max suction Lift Dry	6.0 m
Max Suction Lift Wet	9.8 m
Max Solid passing	3.5 mm
Displacement per cycle	100 cm ³