

Air-Operated Double Diaphragm Pump in Aluminium AODPO25



High Quality Italian Made

Air operated double diaphragm pumps have long been recognized as the most flexible pumps of the industry for handling difficult liquids at relatively low pressures and flows.

- STM Product number AODPO25 in aluminium
- Compression ratio: 1:1
- Max flow-rate: 170 l/min
- Fluid connections: 1" BSP
- Fluids compatible: oil - exhausted oil - diesel fuel
- Gasket: nbr

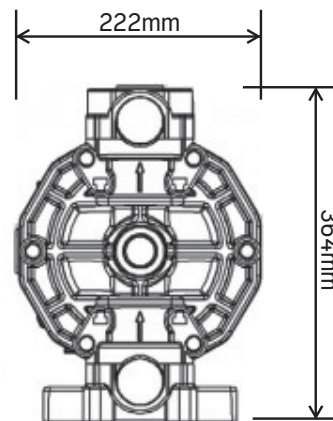
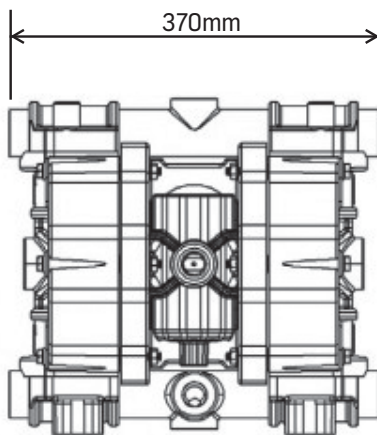

| | |
|-------------------------------|-----------------------------------|
| Pump material | aluminium |
| Diaphragm material | HYTREL |
| Ball material | SS AISI 316 |
| Compatible fluids | OIL - EXHAUSTED OIL - DIESEL FUEL |
| Compression ratio | 1:1 |
| Fluid inlet-outlet connection | 1" BSP |
| Air inlet connection | 1/2" BSP |
| Noise | 75 dB |
| Maximum pressure | 8 bar |

| | |
|------------------------|---------------------|
| Viscosity | 35000 cps |
| Max delivery | 170 l/min |
| Temperature | 95° C |
| Weight | 16 kg |
| Max delivery height | 80 m |
| Max suction Lift Dry | 6.0 m |
| Max Suction Lift Wet | 9.8 m |
| Max Solid passing | 7.5 mm |
| Displacement per cycle | 330 cm ³ |