

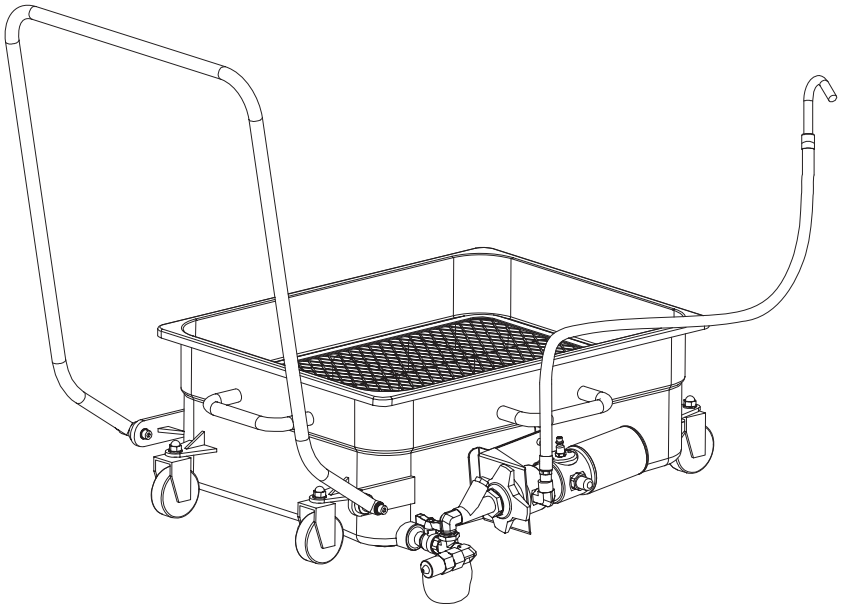

LEADERS IN FLUID TRANSFER SOLUTIONS

# Low Level Drainer With Pump



# OIL DRAINER

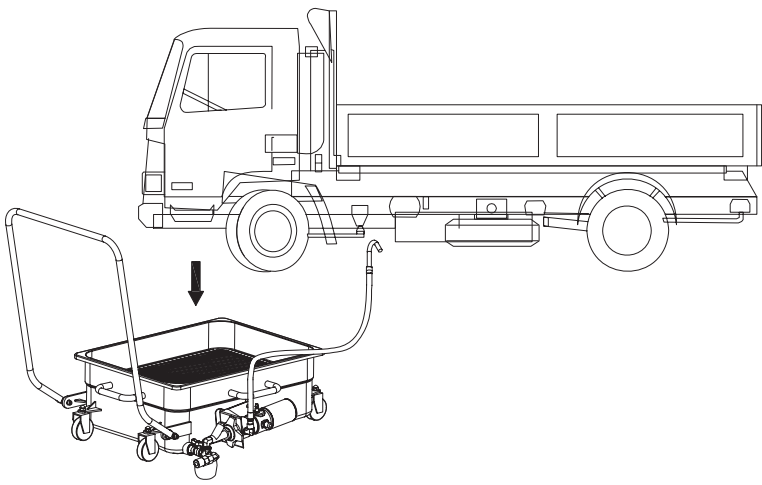
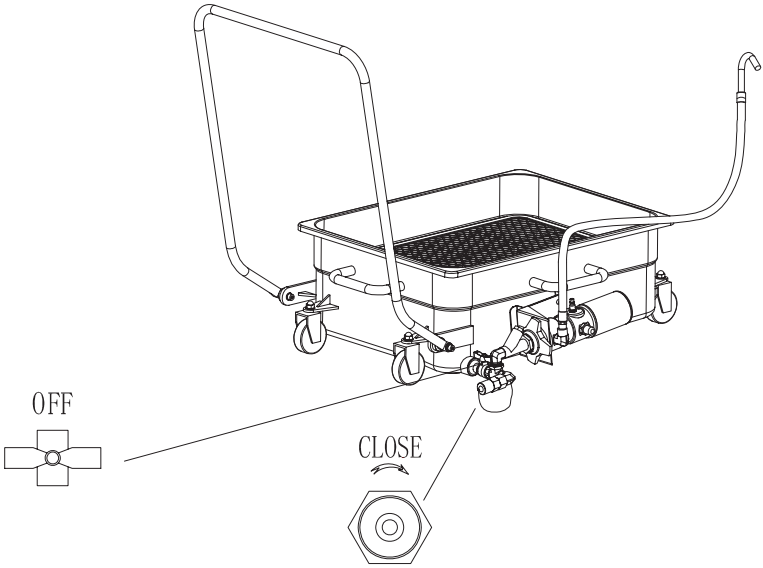

# OIL CHANGER

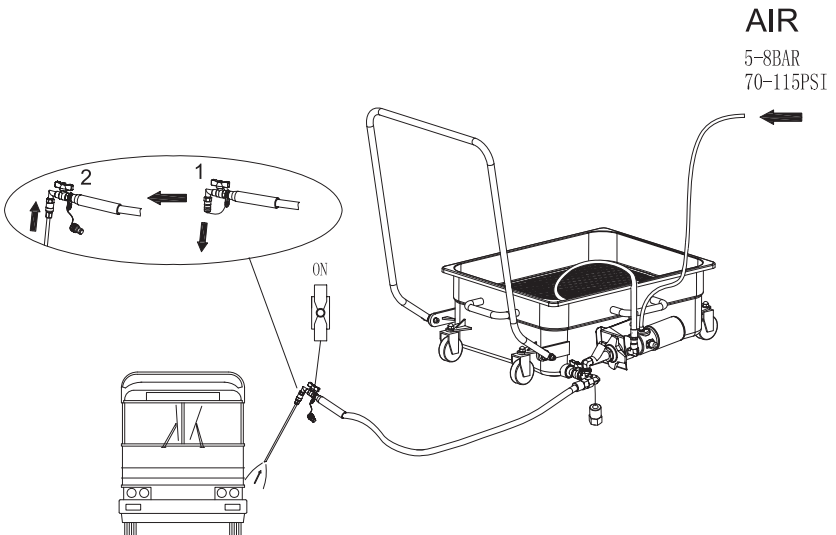
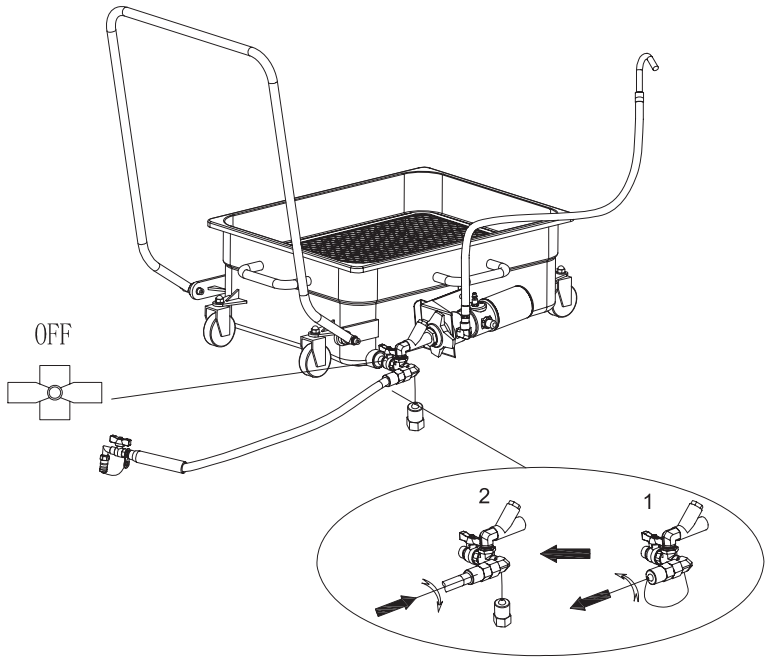

# EXHAUST WASTE OIL

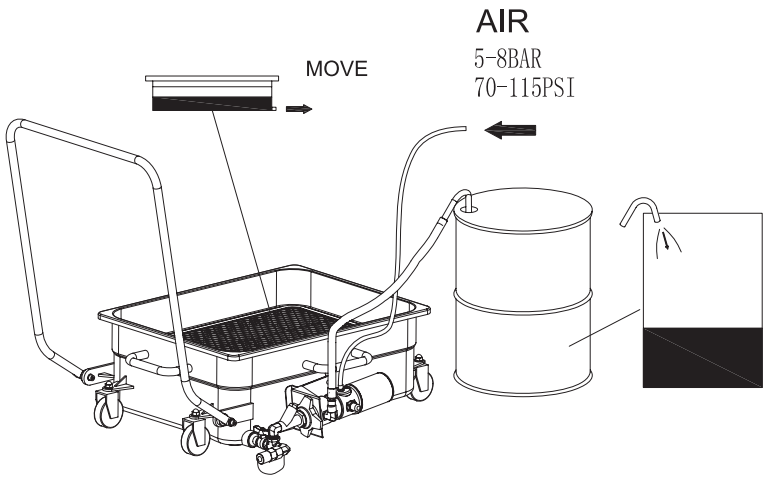
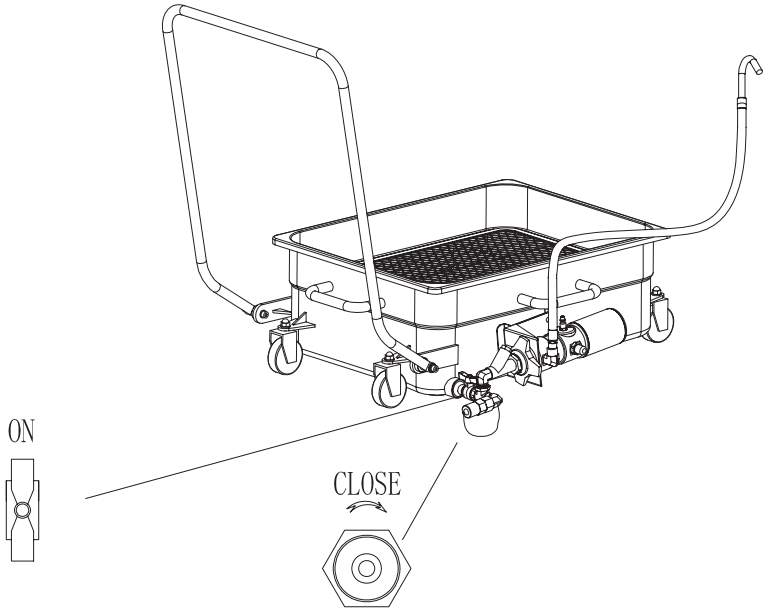

# PARTS EXPLODED

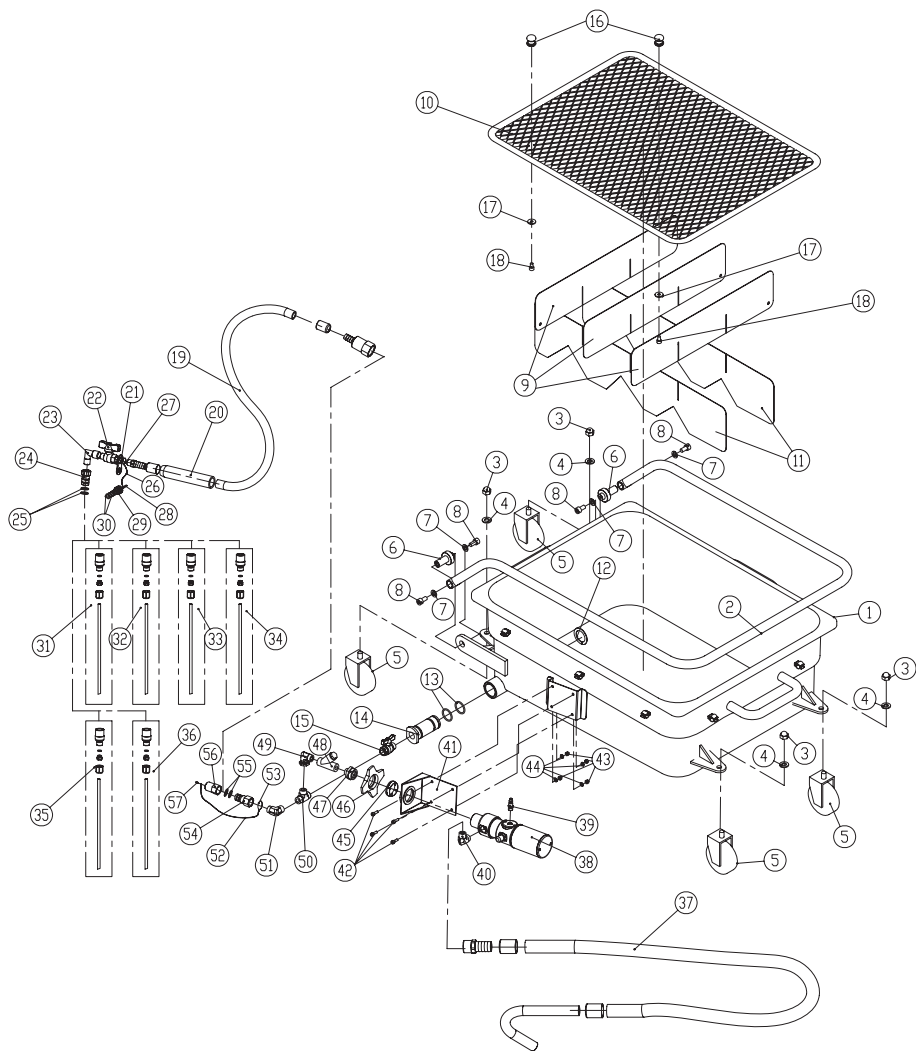

## PARTS LIST

No.	Description	Quantity	No.	Description	Quantity
1	OIL COLLECTING BOWL	1	30	O-RING 6.9X1.8	2
2	HANDLE	1	31	PROBE-5X700 FLEXIBLE	1
3	ACORN NUT M12	4	32	PROBE-6X700 FLEXIBLE	1
4	WASHER 12	4	33	PROBE-7X1000 FLEXIBLE	1
5	SWEVELLING WHEELS	4	34	PROBE-8X700 FLEXIBLE	1
6	PUMP SUPPORT	2	35	PROBE-5X700 MALLEABLE	1
7	WASHER $\phi 8$	4	36	PROBE-6X700 MALLEABLE	1
8	SCREW M8X16	4	37	DISCHARGE HOSE ASS'Y	1
9	TRAVERSE PLATE	3	38	OIL PUMP	1
10	FILTRATING PLANK	1	39	INLET PLUG	1
11	LONGITUDINAL PLATE	2	40	ELBOW FITTING	1
12	SPRING BLOCK	1	41	BRACKET	1
13	O-RING 26.64X2.62	2	42	SCREW	4
14	SUPPORT	1	43	NUT	4
15	BALL VALVE	1	44	WASHER	4
16	HANDLE	2	45	PLASTIC CLAMP	1
17	SCREW M6X10	2	46	BUNG ADAPTER	1
18	WASHER 10	2	47	ADAPTER	1
19	COMPLETE SUCTION HOSE	1	48	FILTER FITTING	1
20	PROTECT SET	2	49	ELBOW FITTING	1
21	POTHOOK	1	50	T-FITTING	1
22	BALL VALVE	1	51	ELBOW FITTING	1
23	ELBOW ADAPTER	1	52	CHAIN	1
24	LINKER	1	53	RING	1
25	O-RING 13.2X1.8	2	54	LINKER	1
26	CHAIN	1	55	O-RING	2
27	RING	1	56	STUFF NUT	1
28	PAN HEAD SCREW	1	57	PAN HEAD SCREW	1
29	STUFF	1			