



LEADERS IN FLUID TRANSFER SOLUTIONS

AC BARREL PUMP MOTOR USER'S MANUAL



WARNING: Read carefully and understand all INSTRUCTIONS before operating. Failure to follow the safety rules and other basic safety precautions may result in serious personal injury.

MODEL NUMBER: 17004501, 17004502

AC BARREL PUMP MOTOR USER'S MANUAL

MODEL NUMBER
17004501 & 17004502

A. SAFETY

All safety instructions must be observed and followed.

Before Using

1. There is high speed rotating components. Failure to follow the safety instructions may lead to serious injury. All safety instructions must be observed and followed strictly.
2. Before installing and starting the barrel pump, the related engineer must have the considerable qualification and is familiar with this manuals.
3. The installation and maintenance must according to the current machinery and electrical standard strictly.
4. The spare parts life time will be limited by wear and corrosion. The failure is affected by operating environment. The user has the responsibility to operate in accordance with the regulations. The regular maintenance and spare parts change should be performed regularly. Stop the pump when the pump under irregularity and obviously dangerous status.
5. The pump should install the detection alarm system when it was installed at the location where may cause the failure or personal injury.

Using

1. Wear protective clothing, goggles and in accordance with the safe production routine when operate the corrosive and hazardous substance.
2. It is prohibited to use plastic or aluminum alloy pump pipe and the non-explosion proof motor when transferring the flammable liquids.
3. Carry flammable liquids, the earth wire must be installed, electrostatic protection device and conductive hose must be used when transferring the flammable liquids.
4. Make sure the pump head insert to the liquids completely before using. Also all the connectors connect tightly. Without leakage and fall out dangerous situation.
5. The suitable flexible pipe must be used during transferring high temperature liquids.
6. Attention to the pumped liquids temperature, viscosity and density do not exceed the stated upper limit.
7. Install the filters in the pump tube bottom when transport the liquids with impurity or solids. To avoid the blocking, please check and clean it regularly.
8. Make sure the motor under close status before power on. Never leave the pump unattended and never operate the motors without pump.
9. Do not touch the tube bottom after switching on the electric or air source. The impeller under high speed rotating may lead to equipment damage and personal injury.

Make sure the pump tube working under vertical position. Never upend or lay flat after using. Pay attention to the residual liquids may lead to injury or cause environmental damage.

B. MACHINE DESCRIPTION

MOTOR: AC series motor with the overheating protection components, Quick coupling adapter, Automatic positioning coupling and Adjustable speed switch.



ATTENTION!

- Never operate the motors without pump.
- Never leave the pump unattended.
- Never run dry of the pump.
- The pump should not be immersed deeper into the liquid than the outlet connection.

C. TECHNICAL DATA

C1. Electrical Data

PUMP MODEL	ELECTRICAL POWER			Load Speed (RMP)	Rated Speed (RMP)
	Current	Voltage(V)	Power (W)		
17004501	AC	230	450	3000~11000	20000
17004502	AC	120	450	3000~11000	20000

D. OPERATING CONDITIONS

D1. Environmental Conditions

Electro-Motor operating environment: -25~40°C

D2. Power Supply

Make sure that the supply voltage corresponds to the voltage indicated on the rating plate.



ATTENTION!

Power from lines with values outside the indicated limits can damage the electrical components.

AC BARREL PUMP MOTOR USER'S MANUAL

MODEL NUMBER
17004501 & 17004502

E. MOVING AND TRANSPORT

The pump tube and motor adopt the carton box packing. There is enough protection packing material inside. However, never knock on, heavy load by the non-normal external force. Please transport and stacking as per packing indication. Keep drying and anti-corrosion of the stacking place.

F. INSTALLATION

Check if the packing was damaged before opening. Make sure no missed spare parts.

Safety Check

Make sure that the supply voltage corresponds to the voltage indicated on the rating plate.

7.1 Motor Installation

1. Pump tube check: Make sure every joint part no looseness. The coupling and shaft could be rotated flexible.
2. Motor Check: Make sure the power cable complete, switch in good condition. Dry running for several minutes to check if the motor workable. Do not put hands to the motor output shaft.
3. Put the motor coupling is directed at the pump tube. Make sure the pump tube head insert to the motor head completely.
4. The motor and pump tube position could be adjusted by 360°. Put the pump tube adjusted to the suitable position and lock the nut to finish the installation. It is recommended that the pump exports away from the motor power cable.

7.2 Start

Make sure all the joint parts without leakage. The tube outlet must be fixed well so to avoid pressure leaking.

F7. Electrical Connections

- Terminal strip box complete of:
 - ON/OFF switch;
 - Speed regulating knob switch
 - Speed regulating circuit board
- 5M Power cable

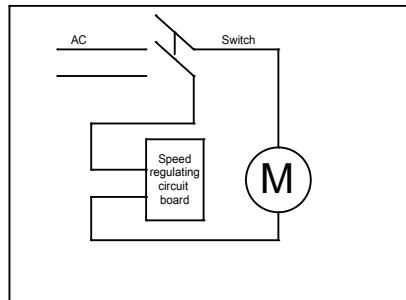

ATTENTION!

IT IS THE INSTALLER'S RESPONSIBILITY TO PREFORM THE ELECTRICAL CONNECTIONS WITH RESPECT FOR THE APPLICABLE REGULATIONS.

G. DAILY USE

Long time continuous running may cause motor overheating, the overheating protection system will cut the power automatically. The motor can be restarted work again after cooling down by pressing the on/off button.



ATTENTION!

The suggested duty cycle is 2 hours. Do not exceed one hour when the environment temperature more than 30° C
Please change the electric brush every 250-300hours

H. NOISE LEVEL

Under normal working conditions the noise emission from all models does not exceed the valve of **80 db at a distance of 1 meter** from the electric pump.

I. DISPOSING OF CONTAMINATED MATERIALS

In the event of maintenance or demolition of the machine, do not disperse contaminated parts into the environment.
Refer to local regulations for their proper disposal.

AC BARREL PUMP MOTOR USER'S MANUAL

**MODEL NUMBER
17004501 & 17004502**

J. PROBLEMS AND SOLUTIONS

PROBLEM	POSSIBLE CAUSE	CORRECTIVE ACTION
No flow rate or small flow rate	Without opening the electric or air source	Open the power and air source
	Motor failure, do not rotating	Motor Check
	Outlet close	Open the outlet valve
	Too big pump lift	Short the transportation distance and height
	Too big liquids viscosity	Check the type with supplier
	Liquids draining out	Stop the pump
	The inlet block off	Clean the inlet
Vibration, Big noise	Liquids draining out	Stop the pump
	Motor overload	Check the liquids viscosity and pump lift
	Sliding bearing damage	Change the sliding bearing and seal ring
	Coupling wear	Change the coupling
Pump tube leakage	Seal ring wear	Change the seal ring
	Circuit failure	Check the circuit
	Long time working of the motor, overheating protection, electric brush damage	Restart the motor after cooling down
		Change the electric brush

K: DIAGRAM & PARTS LIST

No.	Description	Qty.	No.	Description	Qty.	No.	Description	Qty.
1	Tapping screw	3	9	Lining	1	17	Motor	1
2	Speed control knob	1	10	Speed control circuit board	1	18	Cable	1
3	Switch block	1	11	Motor shell	1	19	Coupler	1
4	Countersunk head tapping screw	2	12	Tapping screw	3	20	Bottom cover	1
5	Head cover	1	13	The handle cover	1	21	Flat gasket	3
6	Tapping screw	2	14	Binding post	1	22	Spring washer	3
7	Rotary knob connector	1	15	Wire pressing piece	1	23	Bolt	3
8	Toggle switch	1	16	Cable shield	1	24	Tapping screw	8

AC BARREL PUMP MOTOR USER'S MANUAL

MODEL NUMBER
17004501 & 17004502

