



LEADERS IN FLUID TRANSFER SOLUTIONS

PNEUMATIC OIL DISPENSER





WARNING

Read carefully and understand all INSTRUCTIONS before operating. Failure to follow the safety rules and other basic safety precautions may result in serious personal injury. Save these instructions in a safe place and on hand so that they can be read when required. Keep these instructions to assist in future servicing.



SAFETY PRECAUTIONS

GENERAL SAFETY RULES

WARNING: Read and understand all instructions.

WARNING: The warnings, cautions, and instructions discussed in this instruction manual cannot cover all possible conditions or situations that could occur. It must be understood by the operator that common sense and caution are factors which cannot be built into this product, but must be supplied by the operator.



WARNING

- Do not deliver corrosive or flammable liquids
- Do not expose the tank to heat source
- Do not do welding on the vessel only use the appliance for its intended purpose

OPERATION

- Remove cap (B) and fill the reservoir (4/5 its capacity) with oil, using the funnel supplied
 - Screw cap (B) close ball valve(A). Connect compressed air to quick coupler (D), open the ball valve (K) until manometer (F) gives a pressure of 7-8bar.
 - To deliver oil, open ball valve(A)
- Open the gun set (G) by counter clockwise.

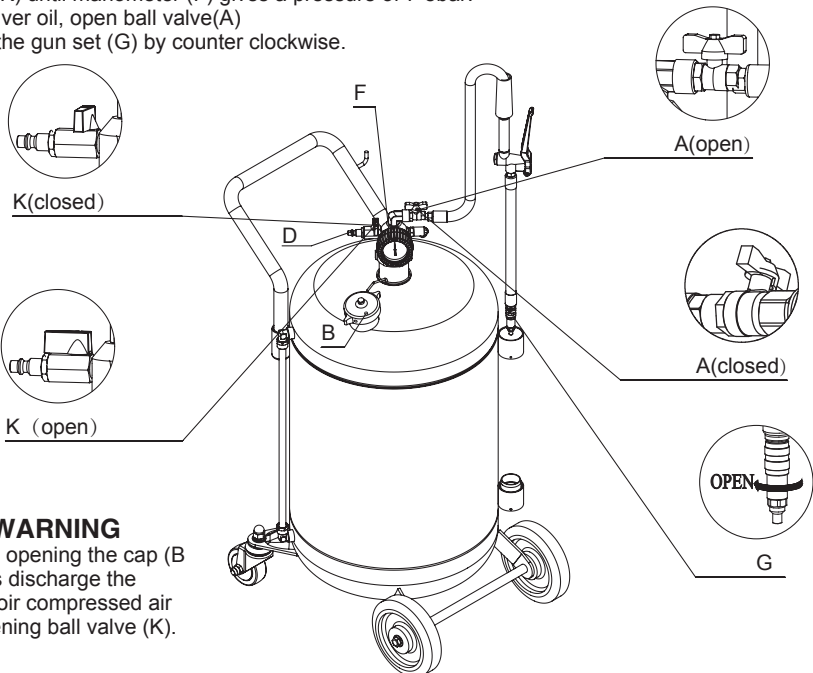

WARNING

- Before opening the cap (B) always discharge the reservoir compressed air by opening ball valve (K).

EXPLODED & PART LIST

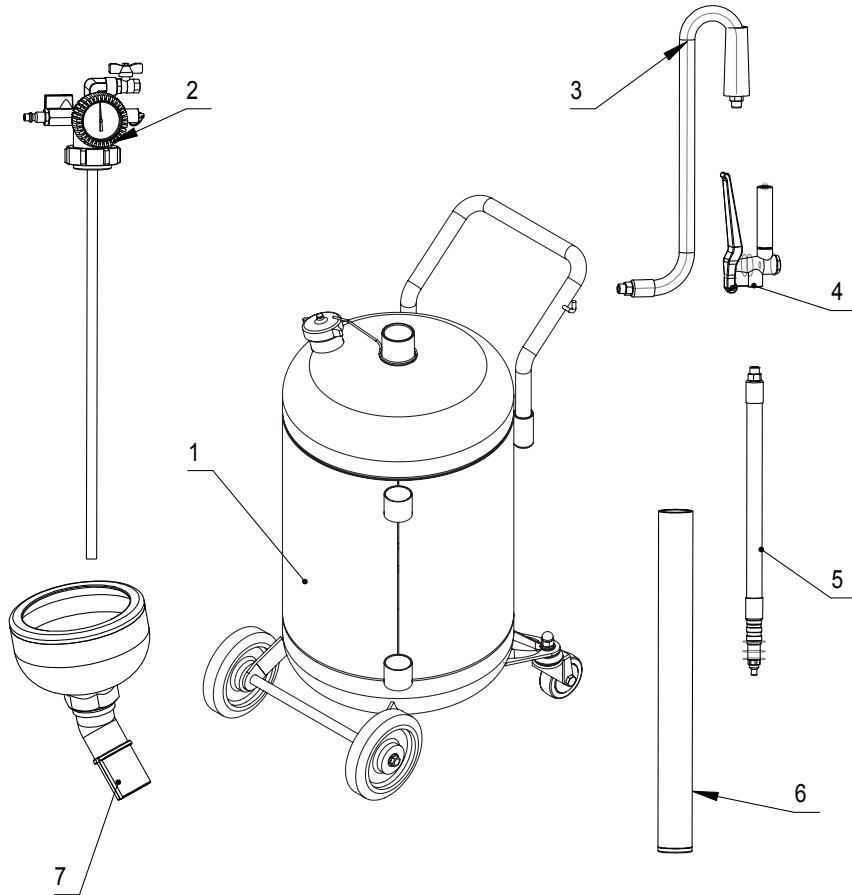

Part No.	Description	Q'ty	Part No.	Description	Q'ty
1	Reservoir	1	*5	Oil filling pipe	1
2	Inlet connector assembly	1	6	Probes container	1
*3	Suction hose assembly	1	7	Funnel	1
*4	Gun	1			

#: Optional accessories
 *: Wearing parts

RESERVOIR & PART LIST

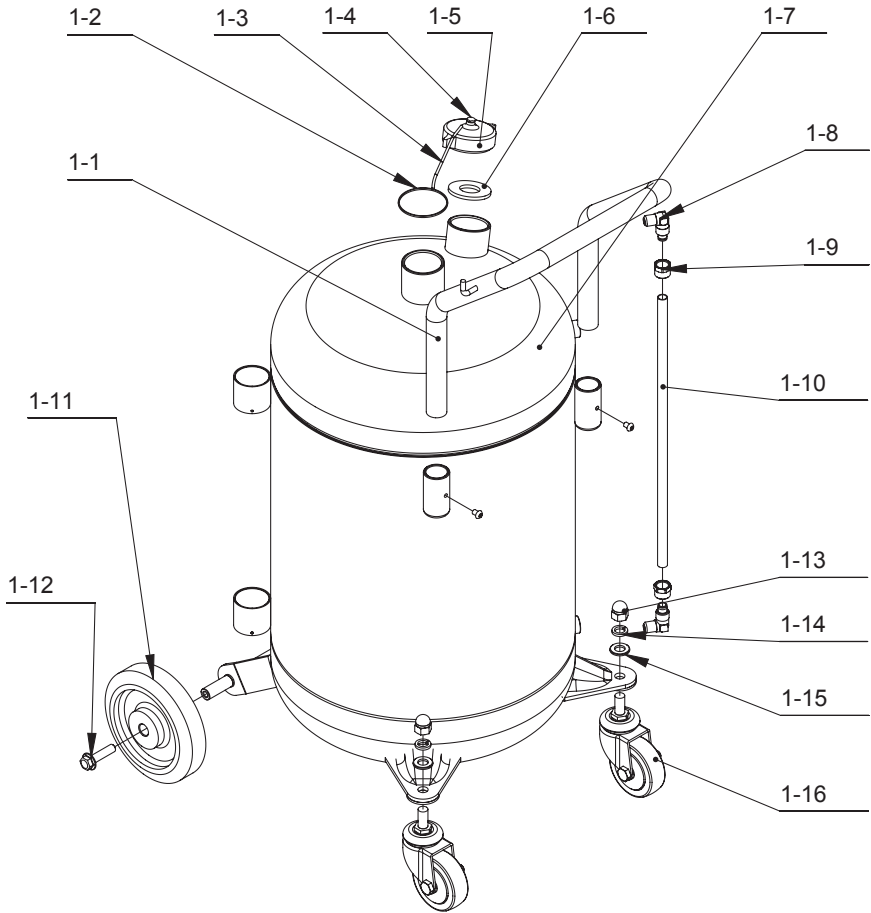

Part No.	Description	Q'ty	Part No.	Description	Q'ty
1-1	Handle	1	1-9	Nut	2
*1-2	Ring	1	1-10	Tube with label	1
1-3	Chain	1	*1-11	Wheels	2
1-4	Round head screws	1	*1-12	Bolt	2
1-5	Pressure plug	1	*1-13	Nuts	2
1-6	Gasket	1	*1-14	Spring washer	2
1-7	Reservoir	1	*1-15	Gasket	2
1-8	Elbow	2	*1-16	Caster	2

#: Optional accessories

*: Wearing parts

INLET CONNECTOR ASSEMBLY & PART LIST

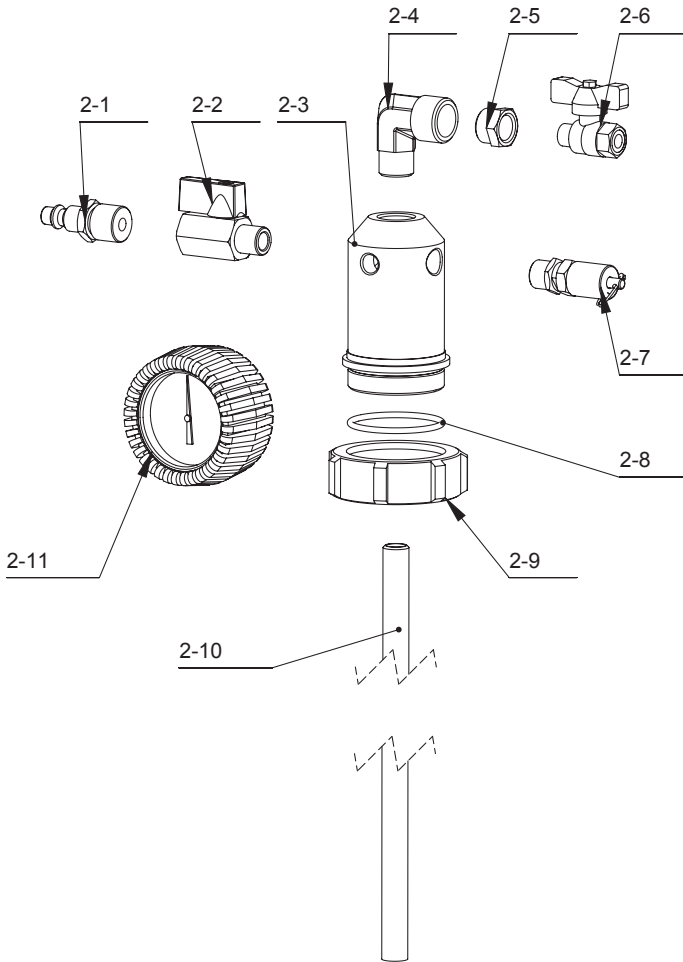

Part No.	Description	Q'ty	Part No.	Description	Q'ty
2-1	Plugs	1	*2-7	Safety valve	1
*2-2	Ball valve	1	*2-8	O-ring	1
2-3	Seat	1	2-9	Round nut with collar	1
2-4	Elbow adapter	1	2-10	Steel tube	1
2-5	Double end adapter	1	2-11	Gauge	1
*2-6	Ball valve	1			

#: Optional accessories

*: Wearing parts